



MEGA STOCKPOT

The Mega Stockpot is design engineered to handle the heaviest loads. Heavy duty construction with Stainless Steel front and sides, they are both attractive and easy to clean. Heavy duty cast iron 3 ring burners rated at 90,000 BTU/hr. give instant high heat while the dual control valves for the inner and outer rings allow maximum flexibility to maintain desired heat settings. A full width drip tray catches spills and allows the lower cabinet to be used for additional storage. You will find that these rugged units will give many years of trouble-free performance.

- *Stainless Steel front and sides.*
- *Heavy gauge construction.*
- *Cast iron 3 ring burner (90,000 BTU/hr.).*
- *Standard pilots for instant ignition.*
- *Dual control valves for inner and outer ring.*
- *Die-cast, chrome plated control knobs.*
- *Full width drip tray to catch spills*
- *Lower cabinet storage cavity.*



The Clay Oven Co. Ltd.
163 Dukes Road, London W3 0SL
Tel: +44 (0) 208 896 2696 Fax: +44 (0) 208 896 2686
www.clayovens.com



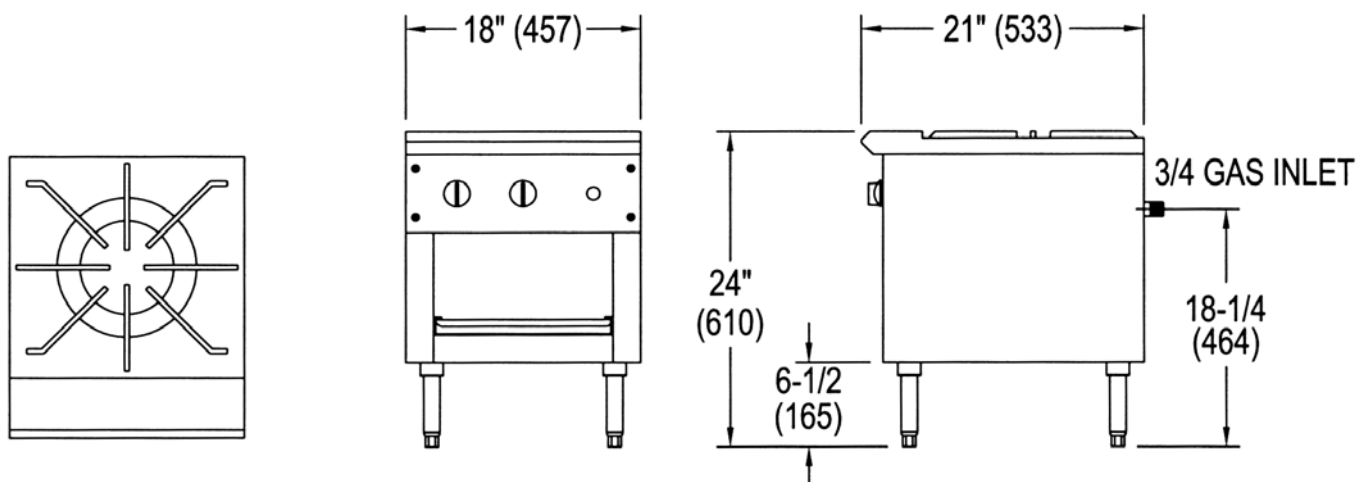

TECHNICAL DATA

Heat Output:

| | |
|---------------------|------------------------|
| High Setting | 90,000 Btu (net) |
| Gas Supply Pressure | 20mbar / 7inch |
| Gas rate | 2.75m ³ /hr |

| Width | Depth | Height | Total Btu | Kw | Ship Lbs. | Kg. |
|-----------|----------|----------|-----------|-------|-----------|-----|
| 451 (18") | 533(21") | 610(24") | 90.000 | 26.37 | 130 | 58 |

Installation Requirements:

Recommended to install under vented hood.

Please Note:

Continuous product improvement is a policy of the Clay Oven Co. Ltd. therefore specification and design are subject to change without notice.



The Clay Oven Co. Ltd.

163 Dukes Road, London W3 0SL

Tel: +44 (0) 208 896 2696 Fax: +44 (0) 208 896 2686

www.clayovens.com